

# MCT-501, MCT-501 T

Advanced Acoustic Sensor / PowerCode Transmitter



**Visonic®**

Installation Instructions

## 1. INTRODUCTION

The MCT-501, MCT-501 T (with back tamper switch) combines two modules:

- The Sentrol Inc. ShatterPro™ acoustic sensor with Pattern Recognition Technology™ (Protected under U.S. Patent 5,192,931)
- The Visonic Ltd. MCT-302 PowerCode™ transmitter

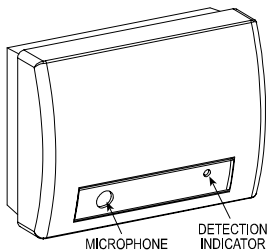

Figure 1. General View

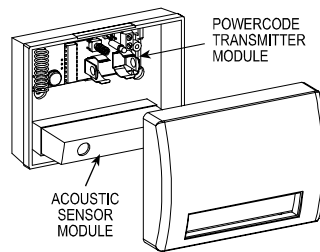

Figure 2. Module Identification

### 1.1 Acoustic Sensor

The acoustic sensor module of the MCT-501, MCT-501 T is omnidirectional, providing 360° coverage. Coverage is measured from the sensor to the point on the glass farthest from the sensor (see Fig. 3). The sensor can be mounted as close as 1 m (3.3 ft) from the glass.

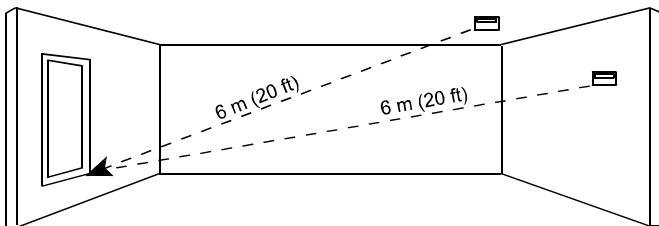

Figure 3. Typical Range Measurement

When mounted on opposite wall or adjoining walls, the range is 6 m (20 ft) for plate, tempered, laminated and wired glass.

When mounted on the ceiling, the maximum range is 6 m (20 ft) for plate, tempered, laminated and wired glass

For armor-coated glass, mount the sensor no more than 3.65 m (12 ft) from the glass.

### 1.2 PowerCode Transmitter

The acoustic sensor shares its housing with a miniature transmitter which has a unique 24-bit PowerCode ID, selected in the factory from over 16 million possible code combinations.

Upon alarm (glass break detection), a digital message is transmitted, composed of the PowerCode ID followed by various status and message-type markers. Alarm and other data are thus forwarded to the wireless alarm control panel.

Since transmitted messages might collide with transmissions from other PowerCode transmitters used in the system, a smart anti-collision transmission sequence is used.

The MCT-501 is protected by a front tamper switch that is activated when the cover is removed. The MCT-501 T is protected by a front tamper switch and back tamper switch that is activated when the base is forcibly detached from the wall. In a tamper situation, a message is transmitted with the "tamper alert" marker ON.

A periodic supervision message, distinguished by a specific marker, is transmitted automatically once in 60 minutes. The wireless control panel is thus informed, at regular intervals, of the sensor's active participation in the system.

A red LED mounted on the transmitter PCB (visible only when the cover is off) lights whenever alarm or tamper events are reported. The LED does not light while a supervision message is being transmitted.

Operating power is obtained from an on-board 3V Lithium Thionyl Chloride battery. A weak battery will cause a "low battery" marker to be added to any message transmitted.

## 2. SPECIFICATIONS

### ACOUSTIC SENSOR SECTION

**Microphone:** Omni-directional electret

**Alarm Duration:** 4 seconds

**RF immunity:** 20 V/m, 1 MHz to 1000 MHz

**Temperature range:** -10° to 50°C (14° to 120°F)

### Recommended Glass Size:

**Minimum:** 0.3 x 0.6 m (1 x 2') or larger glass thickness

**Plate:** 2.4 to 6.4 mm (3/32 to 1/4")

**Tempered:** 3.2 to 6.4 mm (1/8 to 1/4")

**Wired:** 6.4 mm (1/4")

**Laminated:** 3.2 to 6.4 mm (1/8" to 1/4")

### POWERCODE TRANSMITTER SECTION

**Frequency (MHz):** 315, 433.92, 868.95, 869 or other frequencies according to local requirements.

**Transmitter's ID Code:** 24-bit digital word, over 16 million combinations, pulse width modulation.

**Overall Message Length:** 36 bits

**Message Repetition:** One-shot transmission (default) or once every 3 minutes.

**Supervision:** Signaling at 60-minute intervals (U.S. version) or 15 minute interval (UK version), or according to the local standards.

**Response to Tamper Event:** Tamper report every 3 minutes (until the tamper switch is restored).

### POWER SUPPLY

**Power Source:** 3 V Lithium CR-2 type battery, Panasonic or equivalent.

**Nominal Battery Capacity:** 1.2 Ah

**Current Drain:** 24 µA standby, 13 mA on alarm (including LED)

**Battery Life Expectancy:** 3 years (for typical use)

**Battery Supervision:** Automatic transmission of battery condition data as part of any status report.

### PHYSICAL

**Operating Temperature:** 0°C to 49°C (32°F to 120°F).

**Dimensions:** 80 x 108 x 43 mm (3.13 x 4.24 x 1.70 in.).

**Weight (less battery):** 130 g (4.6 oz)

**Housing Material and Color:** Flame retardant ABS, white

**Compliance with Standards:** Meets FCC Part 15, MPT1349, Directive 1999/5/EC and EN 50131-1 Grade 2 (with back tamper switch), Grade 1 (without back tamper switch), Class II.

This device complies with the essential requirements and provisions of Directive 1999/5/EC of the European Parliament and of the Council of 9 March 1999 on radio and telecommunications terminal equipment.

## 3. INSTALLATION

### 3.1 Optimizing Detection and Avoiding False Alarms

For best detection, avoid installing in:

- Rooms with lined, insulating, or sound deadening drapes.

- Rooms with closed wooden window shutters inside.

For best false alarm immunity:

- Avoid 24-hour loop applications (perimeter loop OK).
- Don't use where white noise, such as air compressor noise, is present (a blast of compressed air may cause a false alarm).

- Avoid rooms smaller than 3 x 3 m (10 x 10 ft) and rooms with multiple noise sources such as small kitchens, glass booths noisy areas, garages, small bathrooms, etc.

**Areas to avoid:**

- Glass airlocks and glass vestibule areas
- Noisy kitchens
- Residential car garages
- Small utility rooms
- Stairwells
- Small bathrooms
- Other small acoustically live rooms. For glass break protection in such applications, use shock sensors on the windows or window frames.

**Do Not Install In Humid Rooms** The Wireless MCT-501, MCT-501 T is not hermetically sealed. Excess moisture on the circuit board can eventually cause a short and a false alarm.

**Avoid 24-Hour Loop Applications** The MCT-501, MCT-501 T is recommended for perimeter loops and is designed to function in occupied area. In 24-hour loop applications, where the sensor is armed all day and all night, the false alarm prevention technology will be pushed to its limit. Some sounds can duplicate the glass break pattern the acoustic sensor detects.

Install the MCT-501, MCT-501 T on a perimeter loop which is armed whenever the door and window contacts are armed.

**Protecting Occupied Areas**

The false alarm immunity is best in rooms with only moderate noise. For 24-hour occupied area protection, use shock sensors.

**Proper Testing**

The MCT-501, MCT-501 T is designed to detect the breaking of framed glass mounted in an outside wall. Testing the sensor with unframed glass, broken bottles, etc., may not trip the sensor. The sensor typically does not trip to glass breaking in the middle of the room. No burglar breaks glass in the middle of a room, so such "breaks" are false alarms.

**NOTE:** MCT-501, MCT-501 T may not consistently detect cracks in glass, or bullets which break through the glass. Glass-break sensors should always be backed up by interior protection.

For best false alarm immunity the sensor should be located at least 1.2 m (4 ft) away from noise sources (televisions, speakers, sinks, doors, etc.). The sensor must always be in direct line of sight of all protected windows. It cannot consistently detect glass breaking around corners, in other rooms, etc. Front or back, up or down orientation is not necessary.

**3.2 Sound Travel Considerations**

Since the sound of breaking glass travels directionally out from the broken window, the best location for mounting the sensor is on the opposite wall - assuming the glass to be protected is within the sensor's range and line of sight. The ceiling and adjoining (side) walls are also good sensor locations. A ceiling mounted sensor will have better detection if positioned 2 - 3 m (6 - 10 ft) away from the protected glass into the room.

As with all glass-break sensors, detection is reduced with same-wall mounting, since such detection is partially dependent on glass break sound reflecting off the opposite wall. Test the range with Sentrol 5709C unit held flat against the glass. There may be a reduction in range, depending on room acoustics.

**3.3 Preparing the Unit**

- A. Use a screwdriver to separate the cover from the base, as shown in Figure 4. You will find inside a nylon bag with the battery, two masonry anchors (wall plugs) and two mounting screws.

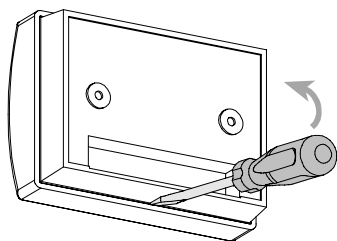

Figure 4. Opening the Unit

- B. Get to know the items indicated in Fig. 5 - they are all relevant to the steps you will have to take in the course of installation.

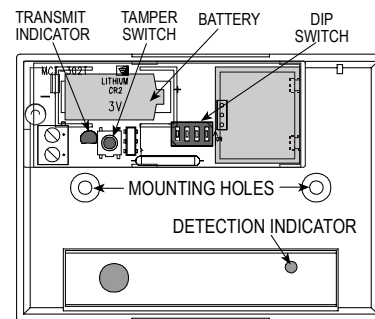

Figure 5. Inside View

- C. Verify that all 4 DIP switch levers are set to OFF as shown in Figure 6 below. If not - set them all OFF.

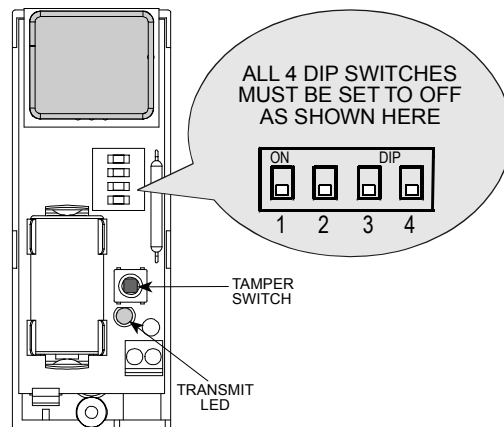

Figure 6. DIP Switches - Correct Position

- D. Insert the battery into the battery clips, as shown in Figures 7 and 8. **Observe Polarity!**

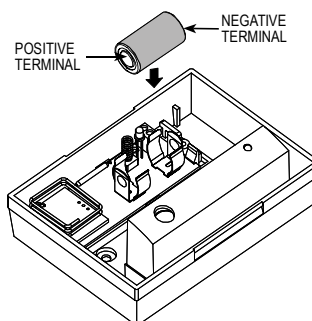

Figure 7. Battery Insertion

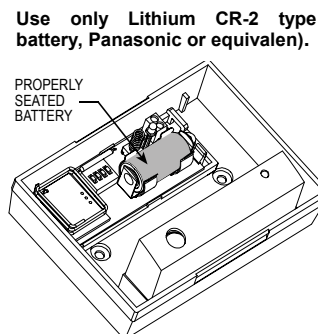

Figure 8. Battery in Place

- E. Click the front tamper switch once and release it to reset the transmitter at power up.

**Note:** Since the cover is removed and power is applied, a tamper situation exists. Verify that the MCT-501, MCT-501 T transmits (the transmit LED lights briefly) once every 3 minutes.

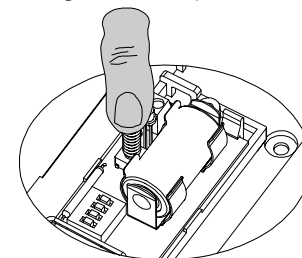

Figure 9. Resetting the Unit

**Attention!** The MCT-501 T has a back tamper switch under the PCB. As long as the PCB is seated firmly within the base, the switch lever will be pressed against a special break-away base segment that is loosely connected to the base (Figure 10). Be sure to fasten the break-away segment to the wall. If the detector unit is forcibly removed from the wall, this segment will break away from the base, causing the tamper switch to open!

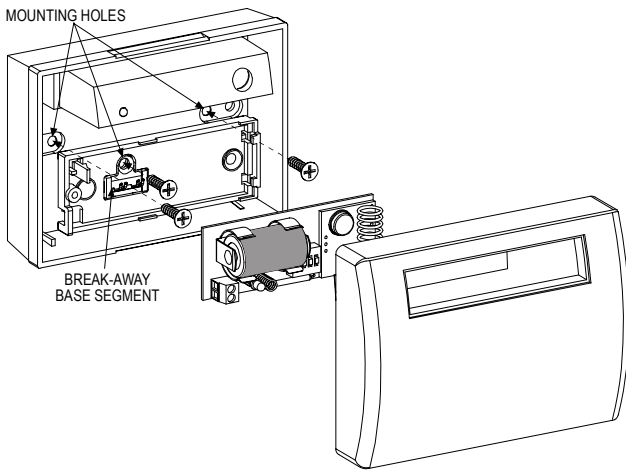

Figure 10. MCT-501 T Internal View

## 4. TESTING PROCEDURES

### 4.1 How Does the Test Mode Works

The Pattern Recognition Technology™ of the MCT-501, MCT-501 T ignores most false alarm sounds, including glass-break testers. In order to test the MCT-501, MCT-501 T, a test mode is used. With the sensor in the test mode, processing of the glass-break pattern in the upper and lower frequencies is disabled. The MCT-501, MCT-501 T is then sensitive only to the mid-range frequencies which the Sentrol 5709C hand-held tester reproduces. It's the mid-range frequencies that determine sensor coverage.

IN THE NORMAL MODE THE DETECTION LED FLASHES BRIEFLY UPON RECEIVING A LOUD SOUND. WHEN IN THE NORMAL MODE, THE MCT-501, MCT-501 T WILL NOT TRIP TO THE TESTER'S SIGNAL, UNLESS THE TESTER IS HELD NEXT TO THE SENSOR.

**NOTE:** Each time the sensor alarms it also goes into the TEST mode for one minute.

### 4.2 Switching the Sensor to the Test Mode

Use the Sentrol 5709C or the Intellisense FG701 hand-held tester to switch the sensor into the test mode. Set the tester to tempered glass, hold the tester speaker directly on top of the sensor and activate the tester. The sensor will alarm, then it will go into test mode for one minute. When in test mode the LED on the sensor will flash continuously. prolong the test session by firing the tester at the sensor at least once a minute.

### 4.3 Testing the Sensor (see Figure 11).

- A. Holding the tester near the surface of the glass, aim the tester at the MCT-501, MCT-501 T and press the test button. If drapes or blinds are present, test with the hand-held tester behind the closed drapes or blinds (do not install the sensor where heavy or lined drapes are used). If the sensor is mounted on same wall, point the tester at the opposite wall.

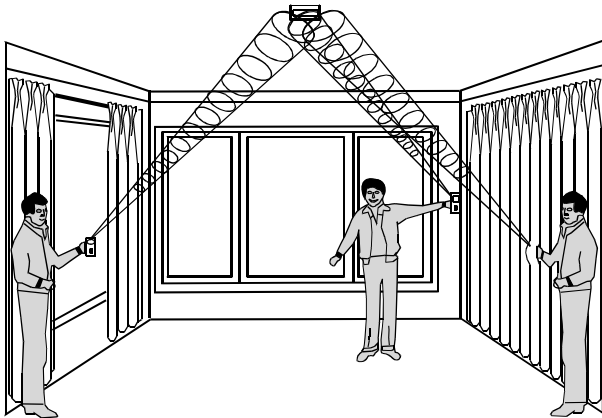

Figure 11. Testing the MCT-501, MCT-501 T

### 3.4 ID Enrollment and Mounting

**Note:** It is much easier to enroll the transmitter ID while holding the MCT-501, MCT-501 T in your hand, close to the control panel.

- A. Refer to the control panel's or PowerCode receiver's installation instructions for enrolling transmitter IDs.
- B. When required to initiate a transmission for enrolling the transmitter's ID, press the unit's tamper switch and release it. The tamper message transmitted as a result (the transmit LED blinks) will do the job.
- C. Use the base as a template - press it against the wall at the selected mounting position and mark the drilling points through the mounting holes. Drill two holes (MCT-501) or three holes (MCT-501 T) and attach the base to the wall using the wall plugs and screws.
- D. Align the cover with the base and push it until it snaps shut.

- B. The tester has a different setting for each type of glass. It should always be set for tempered or laminated glass (either is correct and both have the same range) unless you are certain that all the protected glass is plate glass.
- C. When the LED on the sensor goes solid momentarily while the tester is triggered, the glass is within detection range.
- D. If the LED does not go solid, but continues flashing as before, reposition the sensor closer to the protected windows and retest. This may require adding sensors in order to achieve adequate coverage. It is very rare that the sensor will not activate within its stated range of coverage. Double check adequate battery strength in the hand-held tester. A new tester battery will likely restore the range.

**Note:** The sensor will automatically change from test mode to normal mode approximately one minute after the last signal received from the hand-held tester.

**IMPORTANT!** Room acoustics can artificially extend the range of a glass-break sensor. The specified range of the MCT-501, MCT-501 T has been established for worst-case conditions. While the sensor is likely to function at additional range, it may miss a "minimum output" break, or room acoustics may be changed at some future time, restoring sensor coverage back to the normal range of 6 m (20 ft).

**Do not exceed the rated range of the sensor, regardless of what the tester shows.**

### 4.4 Hand Clap Test

The MCT-501, MCT-501 T can be checked by the installer or end user while in normal mode, simply by clapping hands loudly under the sensor. The LED will flash twice, but the sensor will not trip. This verifies visually that there is power to the sensor, and that the microphone and circuit board are functioning.

The hand clap activation is only momentary, so there is no appreciable effect on battery life.

#### INSTALLATION TIPS

- A. The MCT-501, MCT-501 T is designed to detect the shattering of framed glass mounted in an outside wall. "Testing" the sensor with unframed glass, broken bottles, etc. may not trip the sensor. The MCT-501, MCT-501 T typically does not trip to glass break tests in the middle of a room as such breaks are false alarms.
- B. False alarms are most likely to occur when installed on a 24-hour loop in glass airlocks and glass vestibule areas, when mounted above sinks, when used in residential car garages and in other small, acoustically live rooms and rooms where multiple sounds can reflect and eventually duplicate the glass break frequency pattern. For occupied area glass break protection in such applications, use shock sensors.

C. Installing the MCT-501, MCT-501 T on 24-hour loops will increase false alarms. The MCT-501, MCT-501 T is recommended for perimeter loops and is designed to function without false alarms in occupied areas. On a 24-hour loop, which is armed all day/all night every day, the false alarm technology will be pushed to its limit since some sounds in some conditions can duplicate the points on the glass break pattern that the MCT-501, MCT-501 T detects. Install the MCT-501, MCT-501 T on a perimeter loop, which is armed whenever the door and window contacts are armed. For occupied area installations, MCT-501, MCT-501 T's false alarm immunity is best in rooms with only moderate noise.

D. MCT-501, MCT-501 T detects the shattering of glass. Like all glass-break sensors, it may not consistently detect cracks in glass, or bullets that break through the glass or break out the glass. Glass-break sensors should always be backed up by interior protection.

## 5. MISCELLANEOUS COMMENTS

### 5.1 Product Limitations

Visonic Ltd. wireless systems are very reliable and are tested to high standards. However, due to their low transmitting power and limited range (required by FCC and other regulatory authorities), there are some limitations to be considered:

- A. Receivers may be blocked by radio signals occurring on or near their operating frequencies, regardless of the code selected.
- B. A repeater can only respond to one transmitter signal at a time.
- C. Wireless equipment should be tested regularly to determine whether there are sources of interference and to protect against faults.

### 5.2 Compliance with Standards

This device complies with FCC Rules, Part 15. Operation is subject to two conditions: (1) This device may not cause harmful interference, and (2) this device must accept any interference that may be received or that may cause undesired operation.

**WARNING!** Changes or modifications to this unit not expressly approved by the party responsible for compliance could void the user's authority to operate the equipment.

The digital circuitry of this device has been tested and found to comply with the limits for a Class B digital device, pursuant to Part 15 of the FCC Rules. These limits are designed to provide reasonable protection against harmful interference in residential installations.

This equipment generates, uses and can radiate radio frequency energy and, if not installed and used in accordance with the instructions, may cause harmful interference to radio and television reception. However, there is no guarantee that interference will not occur in a particular installation. If this device does cause such interference, which can be verified by turning the device off and on, the user is encouraged to eliminate the interference by one or more of the following measures:

- Re-orient or re-locate the receiving antenna.
- Increase the distance between the device and the receiver.
- Connect the device to an outlet on a circuit different from the one which supplies power to the receiver.
- Consult the dealer or an experienced radio/TV technician.

This device complies with the essential requirements and provisions of Directive 1999/5/EC of the European Parliament and of the Council of 9 March 1999 on radio and telecommunications terminal equipment.

### 5.3 Frequency Allocations for Wireless Devices in European (EU) Countries

- 433.92 MHz has no restriction in any EU member state.
- 315 MHz is not allowed in any EU member state
- 868.95 MHz (wide band) is allowed in all EU member states.
- 869.2625 MHz (narrow band) is not restricted in any EU member state.

### WARRANTY

Visonic Ltd. and/or its subsidiaries and its affiliates ("the Manufacturer") warrants its products hereinafter referred to as "the Product" or "Products" to be in conformance with its own plans and specifications and to be free of defects in materials and workmanship under normal use and service for a period of twelve months from the date of shipment by the Manufacturer. The Manufacturer's obligations shall be limited within the warranty period, at its option, to repair or replace the product or any part thereof. The Manufacturer shall not be responsible for dismantling and/or reinstallation charges. To exercise the warranty the product must be returned to the Manufacturer freight prepaid and insured.

**This warranty does not apply in the following cases:** improper installation, misuse, failure to follow installation and operating instructions, alteration, abuse, accident or tampering, and repair by anyone other than the Manufacturer.

This warranty is exclusive and expressly in lieu of all other warranties, obligations or liabilities, whether written, oral, express or implied, including any warranty of merchantability or fitness for a particular purpose, or otherwise. In no case shall the Manufacturer be liable to anyone for any consequential or incidental damages for breach of this warranty or any other warranties whatsoever, as aforesaid.

This warranty shall not be modified, varied or extended, and the Manufacturer does not authorize any person to act on its behalf in the modification, variation or extension of this warranty. This warranty shall apply to the Product only. All products, accessories or attachments of others used in conjunction with the Product, including batteries, shall be covered solely by their own warranty, if any. The Manufacturer shall not be liable for any damage or loss whatsoever, whether directly, indirectly, incidentally, consequentially or otherwise, caused by the malfunction of the Product due to products, accessories, or attachments of others, including batteries, used in conjunction with the Products.

The Manufacturer does not represent that its Product may not be compromised and/or circumvented, or that the Product will prevent any death, personal and/or bodily injury and/or damage to property resulting from burglary, robbery, fire or otherwise, or that the Product will in all cases provide adequate warning or protection. User understands that a properly installed and maintained alarm may only reduce the risk of events such as burglary, robbery, and fire without warning, but it is not insurance or a guarantee that such will not occur or that there will be no death, personal damage and/or damage to property as a result.

**The Manufacturer shall have no liability for any death, personal and/or bodily injury and/or damage to property or other loss whether direct, indirect, incidental, consequential or otherwise, based on a claim that the Product failed to function.** However, if the Manufacturer is held liable, whether directly or indirectly, for any loss or damage arising under this limited warranty or otherwise, regardless of cause or origin, the Manufacturer's maximum liability shall not in any case exceed the purchase price of the Product, which shall be fixed as liquidated damages and not as a penalty, and shall be the complete and exclusive remedy against the Manufacturer.

**Warning:** The user should follow the installation and operation instructions and among other things test the Product and the whole system at least once a week. For various reasons, including, but not limited to, changes in environmental conditions, electric or electronic disruptions and tampering, the Product may not perform as expected. The user is advised to take all necessary precautions for his/her safety and the protection of his/her property.

6/91



#### W.E.E.E. Product Recycling Declaration

For information regarding the recycling of this product you must contact the company from which you originally purchased it. If you are discarding this product and not returning it for repair then you must ensure that it is returned as identified by your supplier. This product is not to be thrown away with everyday waste. Directive 2002/96/EC Waste Electrical and Electronic Equipment.



VISONIC LTD. (ISRAEL): P.O.B 22020 TEL-AVIV 61220 ISRAEL. PHONE: (972-3) 645-6789, FAX: (972-3) 645-6788  
 VISONIC INC. (U.S.A.): 65 WEST DUDLEY TOWN ROAD, BLOOMFIELD CT. 06002-1376. PHONE: (860) 243-0833, (800) 223-0020 FAX: (860) 242-8094  
 VISONIC LTD. (UK): 7 COPPERHOUSE COURT, CALDECOTTE, MILTON KEYNES. MK7 8NL. PHONE: (0870) 7300800 FAX: (0870) 7300801  
 INTERNET WEB SITE: [www.visonic.com](http://www.visonic.com)

© VISONIC LTD. 2006 MCT-501, MCT-501 T DE3596- (REV. 4, 05/06)



MADE IN ISRAEL